

- © **Illuminance Range: 0.5 to 199.999 lx with 0.01 lx resolution**
- © **Luminance Range: 2.5 to 199.999 cd/m² with 0.05 cd/m² resolution**
- © **Precise Photometric Matching Detectors**
- © **DIN Class B Parameters**
- © **Compact Size & Ergonomic Design for Mobile Use**
- © **Large Size Display**
- © **High Reliability**
- © **Economical Price**
- © **Battery Operation**
- © **RS232 Interface**
- © **OEM Labeling**

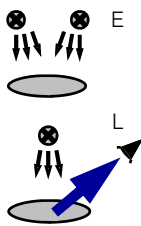

Light Measurement

The most common methods for qualifying light intensity are measuring illuminance in lux or foot-candles and luminance in cd/m² or foot-lamberts. **Illuminance E**, in lx or fc describes the luminous flux per unit area falling on a surface. **Luminance L**, measured in cd/m² or fL describes the brightness of an illuminant or illuminated area.



Light meters with illuminance and luminance detectors are the traditional instruments used in most lighting applications. The wide variety of light sources available today creates problems for light meters calibrated specifically for use with tungsten lamps. Illumination generated by tube lamps with mercury line spectra must also be measured as well as the luminance contrast of monitors used in medical



diagnostics for example. For this reason current DIN and EN regulations specify that light meters must have a maximum permissible error f_{tot} of $\pm 10\%$. According to DIN-5032 Part 7 these are regarded as DIN class B instruments – incidentally many photometers on the market are not certified at all – that are used to measure different types of light sources such as standard illuminant A incandescent lamps,

would yield large uncertainties of measurement.

X9₁ Light Meter

Besides its precision measurement capability the X9₁'s ('Xnineone') most outstanding feature is its easy handling. The LCD characters are 9 mm high for easy viewing. The compact X9₁ is handheld and battery operated. As part of the X9 family it offers a moderate price-performance ratio. This makes it the ideal light measurement tool for safety engineers, service technicians, lighting designers, ISO-certificated companies or anyone who's measured results are subject to audit.

X9₁ Illuminance Meter:

The VL-3704-4 Illuminance detector is fitted with a precise photometric correction filter and

cosine diffuser. Its short height of only 20 mm allows measurement close to the reference level.

X9₁ Luminance Meter:

The LDM-9901-4 Luminance detector offers a field of view of 1° and a measurement range from 40 cm to infinity. To target the object to be measured, the LDM-9901 has notch and bead sight, which has marks for close-range and distance work.

Custom Labeling:

All meters in the X9 family are ready for customization including front panel, modes & detectors. Contact the factory for details.

Operation

The X9₁ is simple to operate. To measure, connect the detector and switch on the meter.

CW Measurement

CW mode is used to measure continuous DC or AC signals .

Peak Hold Measurement

Peak Hold mode is used to search for "hot-spot" light intensity. The peak reading is frozen on the display.

X9 1 Comparison to DIN 5032 Class Limits (%)		Illuminance		Luminance	
		Symbol	X9 ₁	DIN	X9 ₁
Calibration Uncertainty	U_{kal}	1.1	3	1.5	4
$V(\lambda)$ Match	f_1	5	6	5	6
UV Response	u	0.01	2	0.01	2
IR Response	r	0.01	2	0.01	2
Directional Response	f_2	3	3	-	-
Linearity	f_3	0.2	2	0.2	2
Display Unit	f_4	0.1	4.5	0.1	3
Fatigue (at 1 klx)	f_5	0.1	1	0.1	1
Temperature Dependence	f_6	1	10	1	10
Modulated Light	f_7	0.1	0.5	0.1	0.5
Range Change	f_{11}	0.2	1	0.2	1

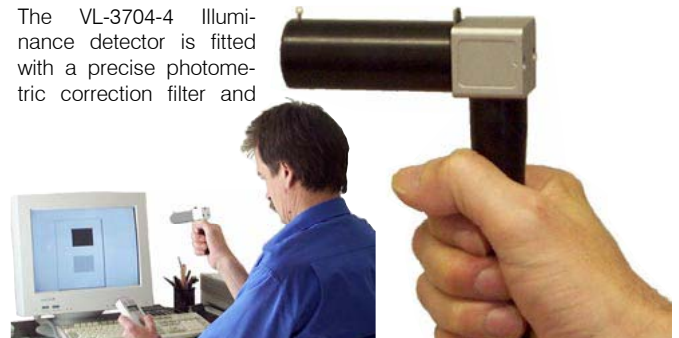

X9₁ Specifications & Ordering Information

Specifications: X9₁ Meter

Signal Input	
Detector Input	Photocurrent to voltage converter amplifier with following voltage to voltage amplifier (x10). 7 decade stepped gain ranges with max. gain signal values from 200.0 μ A to 200.0 pA . Automatic range switching. 12 bit ADC with up to 14 bits at longer integration times.
Signal Processing	A/D converter with 20 ms time interval. 500 ms integration through averaging of multiple measurements.
Frequency Range	Signal conversion from 0.166 Hz to >300 MHz. .
Detector Connector	9 pin MDSM9 socket . Connected detector identification if meter switched ON (VL-3704-4 and LDM-9901-4 only).

Range Specifications				
Range (A/V)	Max. Input Value	Slew-Rate (10 - 90%)	Error (with offset compensation) 1 year, 23°C \pm 5°C \pm (% of reading + % of range),	Permitted Detector Capacitance
1x10-4	200.0 μ A	30 ms	0.2 %* + 0.05 %	2 nF
1x10-5	20,00 μ A	30 ms	0.2 %* + 0.05 %	2 nF
1x10-6	2,000 μ A	30 ms	0.2 %* + 0.05 %	2 nF
1x10-7	200,0 A	30 ms	0.2 %* + 0.05 %	10 nF
1x10-8	20,00 nA	30 ms	0.2 %* + 0.05 %	10 nF
1x10-9	2,000 nA	30 ms	0.2 %* + 0.05 %	10 nF
1x10-10	200,0 pA	30 ms	0.2 %* + 0.05 %	10 nF

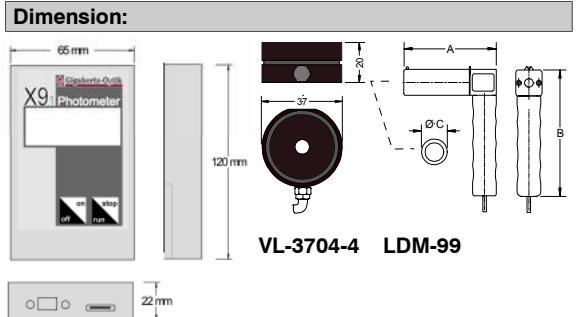

Function	
Parameter Settings	Retention of the last settings in continuous memory. 3 function buttons.
Measurement Quantity	Ampere calibrated with DKD calibrated current source. Current signal multiplied with calibration correction factor to display illuminance in lx and luminance in cd/m ² . Measurement quantity shown in display. Calibration data stored in calibration storage of the meter.
Peak Hold Measurement	Peak measurement value frozen in display. Erased with reset button. Peak mode indicate in display.

General	
Display	6 character LCD. Character height 9 mm. Indication of measurement quantities lx and cd/m ² , battery low, peak, stop
Operating Temperature	5 to 40 °C (41 to 104 ° F) (75 % rel. H, non-condensing). Storage Temperature: 0 to 50°C (32 to 122 °F).
Dimensions/Weight	120 x 65 x 22 mm / 150 g (4.7 x 2.6 x 0.9 in / 0.33 lb).
Power	9 V one-piece battery. Operation time about 100 h. Operation from a AC plug-in power supply 230V/50 Hz on option, erases battery operation.

Interface	
RS232	9600 Baud, 8 8D, 1S,N. 8 pin plug Hirose, type 3260-8S1. Power supply operation recommended for remote control.

Specification: X9 ₁ with VL-3704-4 Illuminance Detector Head	
Typ. Measurement Range	0.5 to 999.999 lx (S/N ratio = 50)
Max. Resolution	0.01 lx
Detector Dimensions	Dia. 37 mm dia.. Height 20 mm; Cos. diffuser dia. 7 mm; Cable length 2 m
Calibration	lx or fc, Factory cal certificate

LDM-9901	
Distance (m)	Spot dia. (mm)
0.5	≈ 31
0.7	≈ 35
1	≈ 41
3	≈ 81
5	≈ 120
10	≈ 220
50	≈ 1000
100	≈ 2000

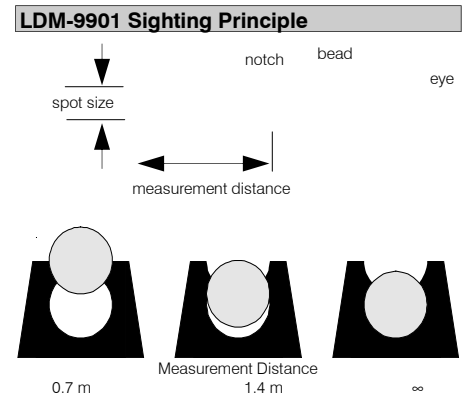

Specifications: X9 ₁ with LD-9901-4 Luminance Detector Head	
Typ. Measurement Range	2.5 to 999.999 cd/m ² (S/N ratio = 50)
Max. Resolution	0.05 cd/m ²
Field of view	1.1°
Measurement Distance	0.4 m to infinity
Detector Dimensions	lens diameter 22 mm; Cable length 1 m
Calibration	Cd/m ² . Factory cal. certificate

Ordering Information	
X9 1	Light Meter lx & cd/m ² without detector heads. Incl. handbook and battery. Detector calibration data stored in memory
X9 1 US	Light Meter fc & cd/m ² without detector heads. Incl. handbook and battery. Detector calibration data stored in memory
VL-3704-4	Illuminance detector. Calibration certificate. ITT-type connector
LDM-9901-4	Luminance detector. Calibration certificate. ITT-type connector
VL-37Z-01	Stand/holder for VL37xx detectors. With bubble and three height adjustable feet. Required to mount detectors to tripods.
VL-37Z-02	Tripod with max. 125 cm height. Without detector mount VL-37Z-01.
LDM-99Z-01	Adapter plate with bubble level to mount and align the LDM-9901luminance detector onto standard tripods.
LDM-99Z-02	Ambient light shade made by elastic rubber to place the LDM-99 direct on the monitor face.
X9Z-01	RS232 interface cable to connect the X9 meters with 9 PIN SUB-D PC standard socket.
X9Z-02	External power unit for the X9 meters including meter modification (cancels battery operation)
BHO-04	Hard case to carry and store the X9 1 with one VL-3704 and LDM-9901